



## ST. TAMMANY PARISH

PATRICIA P. BRISTER  
PARISH PRESIDENT

**April 12, 2019**

Please find the following addendum to the below mentioned BID.

**Addendum No.:** 2

**Bid#:** 19-17-2

**Project Name:** LED Lighting

**Bid Due Date:** April 17, 2019

### **GENERAL INFORMATION:**

---

1. Please delete Specifications and Pricing Sheet REVISED and replace with Specifications and Pricing Sheet –REVISED-2 (Attached). The following lighting has been added to the bid.
  - Porter Industry, Model# 22AP3240A is an approved equal for Item- 7 (Attached)
  - Porter Industry, Model# 24AP5040A is an approved equal for Item- 8 (Attached)
  - American Green Lighting, Model# FD-45W-27V-50K-5-B77 is an approved equal for Item-10 (Attached)
  - Porter Industry, Model# UFO10-100W-110-H-50K is an approved equal for Item-13 (Attached)
2. Item# 11, make or approved equal name for Model # R20FL6/827/LED was changed from PROLED to HALCO.

### **ATTACHMENTS:**

---

1. Specifications and Pricing Sheet –REVISED-2 .pdf
2. Attachments:
  - Porter Industry, Model# 22AP3240A .pdf
  - Porter Industry, Model# 24AP5040A .pdf
  - American Green Lighting, Model# FD-45W-27V-50K-5-B77 .pdf
  - Porter Industry, Model# UFO10-100W-110-H-50K .pdf



**ST. TAMMANY PARISH**  
PATRICIA P. BRISTER  
PARISH PRESIDENT

**<< End of Addendum 2 >>**

## **LED Lighting**

### **Bid # 19-17-2**

#### Specifications and Pricing Sheet-REVISED 2

The Parish is soliciting proposals for the purchase of new LED lighting. Prices remain in effect through **December 31, 2019**, with the option to extend for (1) one additional year, by written agreement of both parties. Any delivery and/or service charges must be included in the bid price. Quantities may vary; minimum orders shall not be required. St. Tammany Parish Government (Parish) reserves the right to award materials in whole, in part and/ or to multiple vendors. Bids must be submitted on the Pricing Sheet provided. **All fields must be filled in, NO blanks will be permitted. If the item is unavailable, enter N/A.**

The Parish facilities are comprised of buildings acquired over time which may require items not anticipated in this bid proposal request. In the event additional items and/or upgraded items are required by the Parish, the Bidder may provide the items with prior written approval by the Parish.

#### **Delivery Locations:**

Deliveries may need to be made to Parish facilities within St. Tammany Parish in addition to the following locations:

- Facilities Management, 21410 Koop Drive, Building C-1<sup>st</sup> Floor, Mandeville, LA 70741
- Justice Center, 701 N. Columbia St., Covington, LA 70433
- Safe Haven, 23592 Sparrow Road, Mandeville, LA 70448

Where specified on the bid sheets, prices shall be for the approved brand/states manufacturer or a prior approved equal by the Parish. Where the specifications do not indicate an approved brand for an item, the Parish has no preference. The name of any manufacturer mentioned in the specifications is for the purpose of establishing a minimum acceptable standard of quality desired by the Parish. All products bid must have prior approval as “approved equivalents”.

Should the Bidder desire to submit inquiries and/or request approval of an alternative product, Bidder shall submit make, model, supply catalog cut sheets and descriptive literature for the alternative product to the Procurement Department via email to [purchasing@stpgov.org](mailto:purchasing@stpgov.org) by 2:00 PM within seven (7) business days prior to the bid opening. Requests for approval of alternative products, shall include a copy of the bid and clearly identify the item(s) for which the equivalent item is being requested. The Parish shall review the inquiry and/or request for “approved

**LED Lighting**

**Bid # 19-17-2**

Specifications and Pricing Sheet-REVISED 2

equivalent” and issue an addendum within three (3) business days prior to the bid opening if prior approval submission is accepted as equivalent.

Bidder **must** acknowledge all addenda by entering the number the Parish assigned to EACH of the addenda that the Bidder is acknowledging.

The Bidder acknowledges receipt of the following:

**ADDENDA:** \_\_\_\_\_

**All fields must be filled in. NO blanks will be permitted. If the item is unavailable please enter N/A. “Price/Each” shall represent the cost for the specified item as well as any delivery charges (if applicable) to the location(s) indicated in this bid.**

<p align="center"><b>LED Lighting                      BID #19-17-2                      Specifications and Pricing Sheet -REVISED 2</b></p>					
Ref No.	Description	Make or Approved Equal	Approved Model No.	ea	Unit Price
Item-1	<b>4' LED tube</b> <17 watts Max - DIRECT WIRE -Bi-Pin base- Aluminum (No Glass) - 1800 lumens - 4000K (DLC CERTIFIED)	James Industry	ZY-T8-15W1200 BIXX	1	
		NaturaLED	LED15T8/FR18/840	1	
		TGS	834115-40-AB-P	1	
		WALSTAR	WL-T8A-15W1200 DIAB-40	1	
Item-2	<b>LED WALLPACK</b> half cutoff LED <105 watts >10,200 lumens 5000k IP65 <i>With PHOTOCELL</i> (DLC CERTIFIED)	LEDone	LOD-WP90W-50K	1	
		SYHDEE	SYHU-WP090NNXH-B(5000k)	1	
		NaturaLED	LED-FXTWP80/50K/DB	1	
		Sylvania Lighting	WALPAK3N/105UNV750/NC/BZ	1	

## LED Lighting

### Bid # 19-17-2

#### Specifications and Pricing Sheet-REVISED 2

		HALCO	WP2/CL90UBZ50/PC	1	
Item-3	<b>PAR38 LED FLOOD BULB</b> >1000 lumens <18 watts 4000K E26 base(DLC/ES CERTIFIED)	GE	LED18D38OW384040	1	
		NaturaLED	LED15PAR38/OD/120L/FL/940	1	
		Sylvania Lighting	LED14APR38/DIM/840/FL40/22Y/GL3/W/RP	1	
		HALCO	PAR38FL15/840/ECO2/LED	1	
Item-4	<b>BR30 LED FLOOD BULB</b> >700 lumens <12 watts 4000K E26 base (DLC/ES CERTIFIED)	GREEN CREATIVE	8BR30G4DIM/840	1	
		TCP	LED12BR30D41K	1	
		HALCO	BR30FL10/840/LED	1	
Item-5	<b>BELLY PAN retrofit kit or 8' Conversion fixture</b> - for 8' fixtures - kit makes 2 8' T8/T12 in to 4 - 4' LED tubes (No certification required)	Epco	14050	1	
		X1LED	C2328X1	1	
		TGS	9919-4-A-C	1	
Item-6	<b>INCANDESCENT style LED bulb</b> <12 watts >800 Lumens 2700K/4000K (Order dependant)(DLC/ES CERTIFIED)	GE	LED10DA19/827	1	
		TCP	L60A19N1541K	1	
		Sylvania Lighting	LED9A19DIMO827U	1	
		HALCO	A19FR9/840/OMNI2/LED	1	
Item-7	<b>2 X 2 LED FLATPANEL</b> -4000K >2500 Lumens <40 watts (DLC CERTIFIED)	GreenTek	GT22-30W-CDS ADVANCED	1	
		NaturaLED	LED-FXPNL25/2X2/840	1	
		Sylvania Lighting	PANELF1A/032UNVD840/22G/WH	1	
		HALCO	22EPL30/840/LED	1	

## LED Lighting

### Bid # 19-17-2

#### Specifications and Pricing Sheet-REVISED 2

		Porter Industry	22AP3240A	1	
Item-8	<b>2 X 4 LED FLATPANEL</b> -4000K 4200 Lumens <60 watts (DLC CERTIFIED)	GreenTek	GT24-40W-CDS ADVANCED	1	
		NaturaLED	LED-FXPNL40/2X4/840	1	
		Sylvania Lighting	SYL PANELF1A/040UNVD840/24G/	1	
		HALCO	24EPL50/840/LED	1	
		RAB	EZPAN2X4-50N/D10	1	
		Porter Industry	24AP5040A	1	
Item-9	<b>LED Cobrahead Style Roadway/Street light</b> - 5000K 10,000 lumens photocell included <120 watts (DLC CERTIFIED) Multi mount IP65	WESTGATE	STL-90W-50K-P	1	
		ENERGETIC LIGHTING	E1STA100L-750	1	
		HALCO	AL100/T4U50/7PRS	1	
Item-10	<b>LED Flood Fixture</b> - 5000 Lumens 5000K <60 Watts Multi Mount IP65 (DLC Certified)	GreenTek	GT-FL06-50WAT1A1-57K	1	
		GREEN INOVA	GI-FL050A-50-B	1	
		Sylvania Lighting	SLMFLD1A/050UNV840/WF/BZ	1	
		HALCO	FL2/CL48BZ50/KN/LED	1	
		American Green Lighting	FD-45W-27V-50K-5-B77	1	
Item-11	<b>R20 LED lamp</b> - 400 Lumens - 2700K 8 watts max	HALCO	R20FL6/827/LED	1	
		G.E.	LED7DP203B827/35	1	
Item-12	<b>Elevator LED R12 lamp</b> - 120 lumens 10-18 volts- BA15S base - 2700k	HALCO	1383/3WW/LED	1	
		LED ElevatorLight	LP02D44FL2	1	

## LED Lighting

### Bid # 19-17-2

#### Specifications and Pricing Sheet-REVISED 2

		EIKO	LED3W1383/30/830-G5		1
Item-13	<b>UFO style High Bay - 12,500 Lumens, 5000k, &lt;120 watts, Multi Voltage input (DLC Certified)</b>	TGS	CHB-E-100W-50K-W	1	
		ATG Electronics	HBUF-100W-50-C	1	
		Porter Industry	UFO10-100W-110-H-50K	1	
<b>All products must be DLC/Energy Star Certified where applicable and have a minimum 3 year Warranty</b>					

Company \_\_\_\_\_

Signature \_\_\_\_\_ Date: \_\_\_\_\_

Print Name \_\_\_\_\_

Title \_\_\_\_\_

Address \_\_\_\_\_

Telephone \_\_\_\_\_ email: \_\_\_\_\_

NOSC Alternate for ~~LED-07~~ Item-7

pg 1/2

Project: ST Tom Bld #19-17-2

Notes:

Type: \_\_\_\_\_ Date: \_\_\_\_\_

Catalog #: PT-FPA-22/32W-4K-P

# PORTOR INDUSTRY

## LED SLIM FLAT PANEL

## 22AP32 SERIES

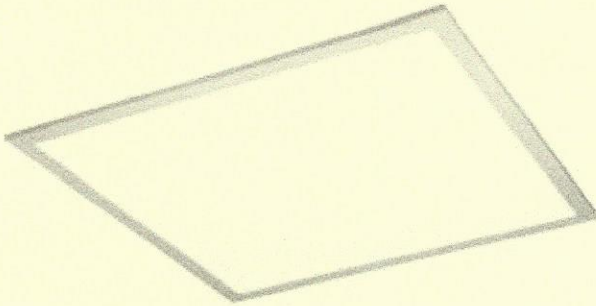

### APPLICATIONS

- Hotels
- Commercial
- Factories
- Churches
- Schools
- Super Markets
- Shopping Malls
- Interior Lighting
- Meeting Rooms
- Institutional Areas
- Retail Areas



### SPECIFICATION FEATURES

#### CONSTRUCTION

Powder-coat Paint extruded aluminum frame with Acrylic Multi-Layered Panel System. Fire-Proof Junction Box with knockout on backside.

#### ELECTRICAL

Luminaire is built with the highest quality 100-277VAC Universal Drivers and High Lumen LED Chips. Beam angle is 110°.

#### ENERGY SAVINGS

50% more energy savings than fluorescent tubes. Low heat production requires less air-conditioning requirements.

#### CONTROLS AND DIMMING

0-10V Dimmable Standard.  
EM Capable via Field Installation.

#### INSTALLATION

Fixture installs easily in 3 steps which equals in labor cost savings. Light weight makes for easy lifting into drop ceilings or surface mounting.

#### CERTIFICATION AND WARRANTY

UL Listed, FCC, CE, & DLC Premium Listed on QPL.  
5 Year Warranty

### MODEL NUMBER(S)

MODEL #	WATTS	LUMENS PER WATT	LUMENS	COLOR TEMPERATURE	CRI	LIFE HOURS	INPUT VOLTAGE
<b>DLC #</b> 22AP3240A	32	131	4,200	4000K	80	50,000	AC 100/277V
22AP3250A	32	132	4,250	5000K	80	50,000	AC 100/277V



**LED SLIM FLAT PANEL**

**22AP32 SERIES**

**DIMENSIONS**

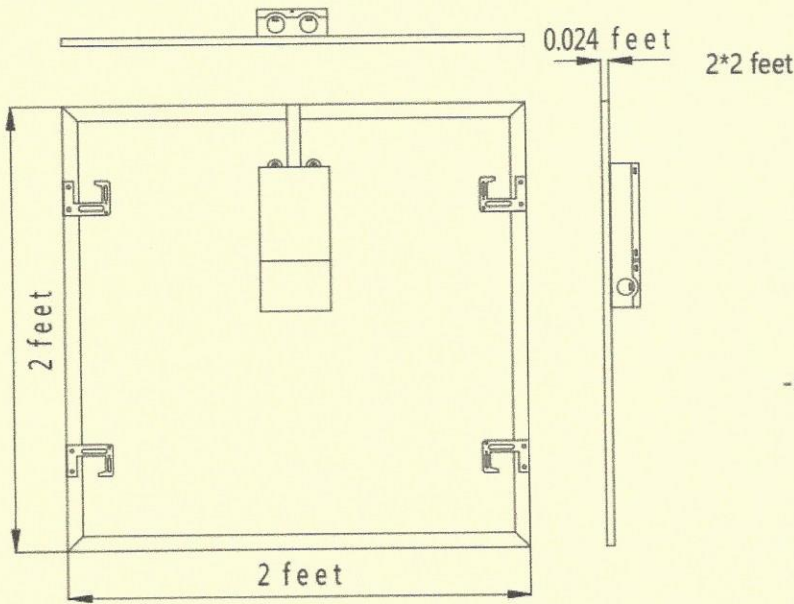

**PHOTOMETRIC DATA**

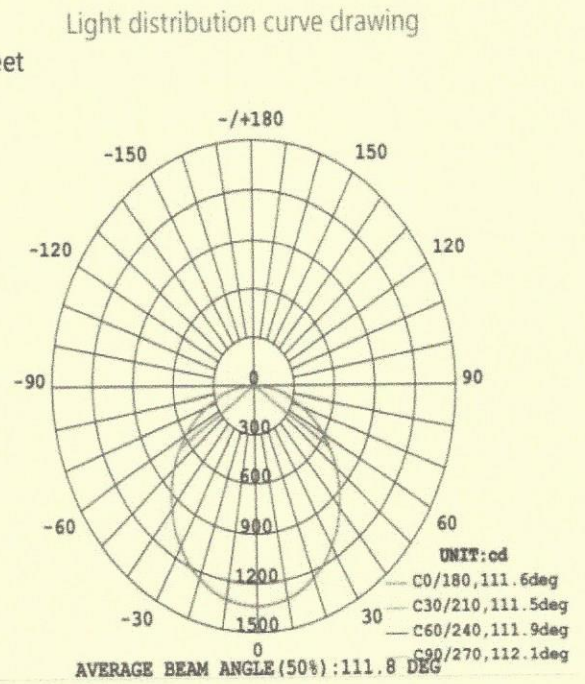

**TECHNICAL SUMMARY**

22AP32	
INPUT WATTS	32 Watts
INPUT VOLTAGE	AC 100 - 277V
POWER FREQUENCY	50 Hz
EFFICACY	130 lm/W
DELIVERED LUMENS	4,200 LM
CCT	4000K / 5000K
CRI	RA>80
DRIVER / CHIPS	Lifud / SMD 2835
LIGHT GUIDE PLATE	PMMA * *
IP RATING	IP40 Rating
CERTIFICATION	UL CE FCC DLC Premium
WARRANTY TIME	5 Years
OPTIONAL ACCESSORY	EM Battery Backup / Surface Mount Kit
DIMMABLE	0 - 10V
POWER FACTOR	>0.95
THD	≤15%
PORTOR ITEM NUMBER	PT-FPA-22/32W

illumination distribution drawing

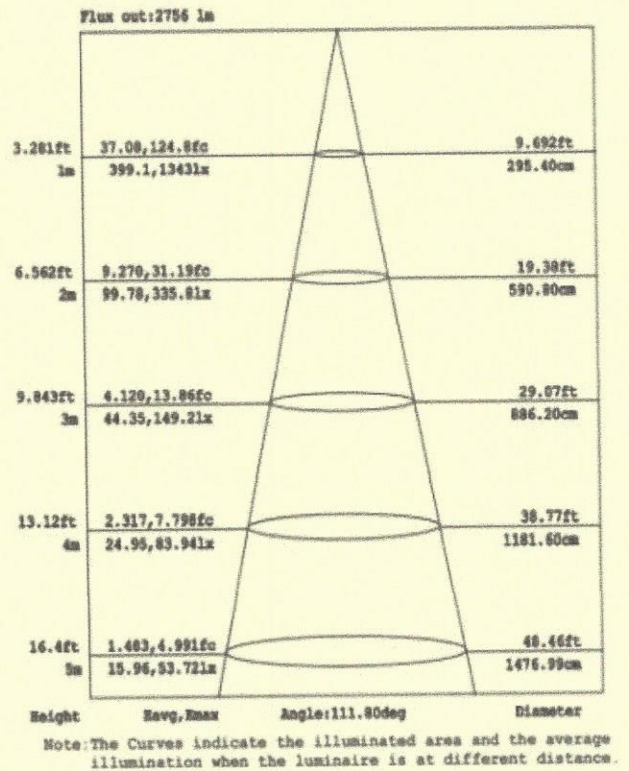

Project: ST Tam Bid #19-17-2

Notes:

Type: \_\_\_\_\_ Date: \_\_\_\_\_

Catalog #: PT-FPA-24/50W-4K-P

# PORTOR INDUSTRY

## LED SLIM FLAT PANEL

## 24AP50 SERIES

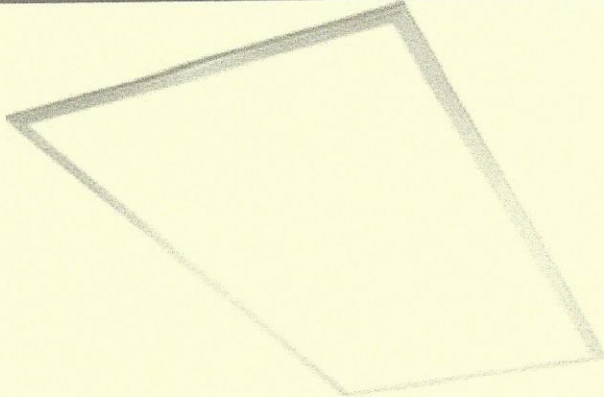

### APPLICATIONS

- Hotels
- Commercial
- Factories
- Churches
- Schools
- Super Markets
- Shopping Malls
- Interior Lighting
- Meeting Rooms
- Institutional Areas
- Retail Areas



### SPECIFICATION FEATURES

#### CONSTRUCTION

Powder-coat Paint extruded aluminum frame with Acrylic Multi-Layered Panel System. Fire-Proof Junction Box with knockout on backside.

#### ELECTRICAL

Luminaire is built with the highest quality 100-277VAC Universal Drivers and High Lumen LED Chips. Beam angle is 110°.

#### ENERGY SAVINGS

50% more energy savings than fluorescent tubes. Low heat production requires less air-conditioning requirements.

#### CONTROLS AND DIMMING

0-10V Dimmable Standard.  
EM Capable via Field Installation.

#### INSTALLATION

Fixture installs easily in 3 steps which equals in labor cost savings. Light weight makes for easy lifting into drop ceilings or surface mounting.

#### CERTIFICATION AND WARRANTY

UL Listed, FCC, CE, & DLC Premium Listed on QPL.  
5 Year Warranty

### MODEL NUMBER(S)

MODEL #	WATTS	LUMENS PER WATT	LUMENS	COLOR TEMPERATURE	CRI	LIFE HOURS	INPUT VOLTAGE
DLC # 24AP5040A	50	130	6,450	4000K	80	50,000	AC 120/277V
24AP5050A	50	130	6,475	5000K	80	50,000	AC 120/277V

# LED SLIM FLAT PANEL

# 24AP50 SERIES

## DIMENSIONS

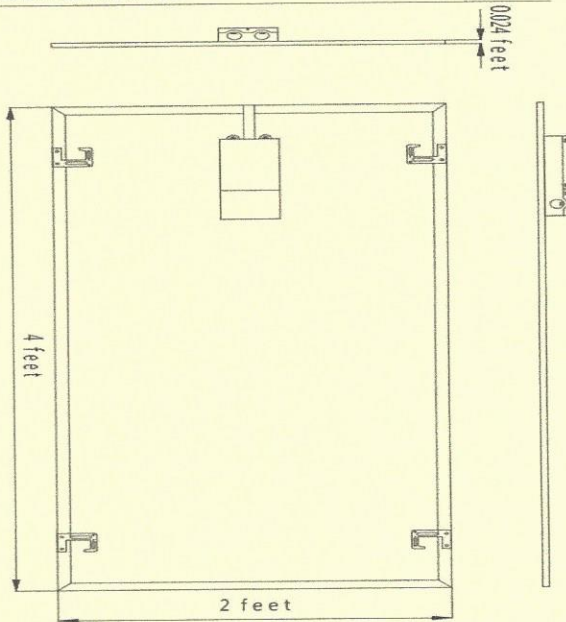

## PHOTOMETRIC DATA

2\*4 feet

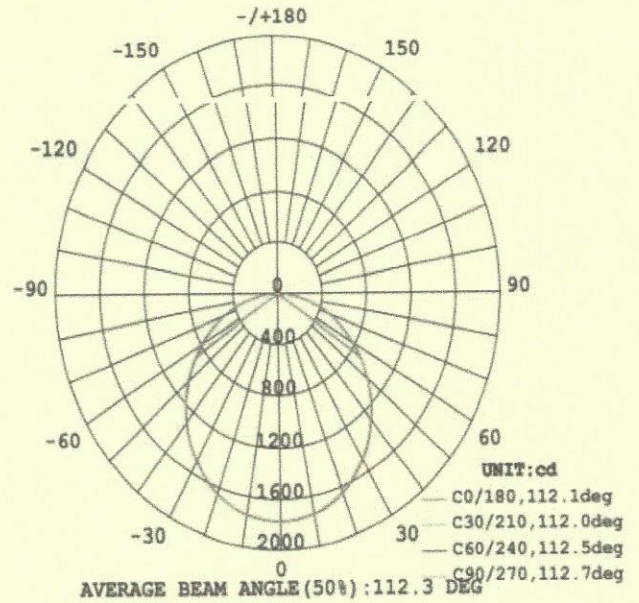

## TECHNICAL SUMMARY

24AP50	
INPUT WATTS	50 Watts
INPUT VOLTAGE	AC 120 — 277V
POWER FREQUENCY	50 Hz
EFFICACY	130 lm/W
DELIVERED LUMENS	6,350 LM
CCT	4000K / 5000K
CRI	RA>80
DRIVER / CHIPS	Lifud / SMD 2835
LIGHT GUIDE PLATE	PMMA * *
IP RATING	IP40 Rating
CERTIFICATION	UL CE FCC DLC Premium
WARRANTY TIME	5 Years
OPTIONAL ACCESSORY	EM Battery Backup /Surface Mount Kit
DIMMABLE	0 – 10V
POWER FACTOR	>0.95
THD	≤15%
PORTOR ITEM NUMBER	PT-FPA-24/50W

## Illumination distribution drawing

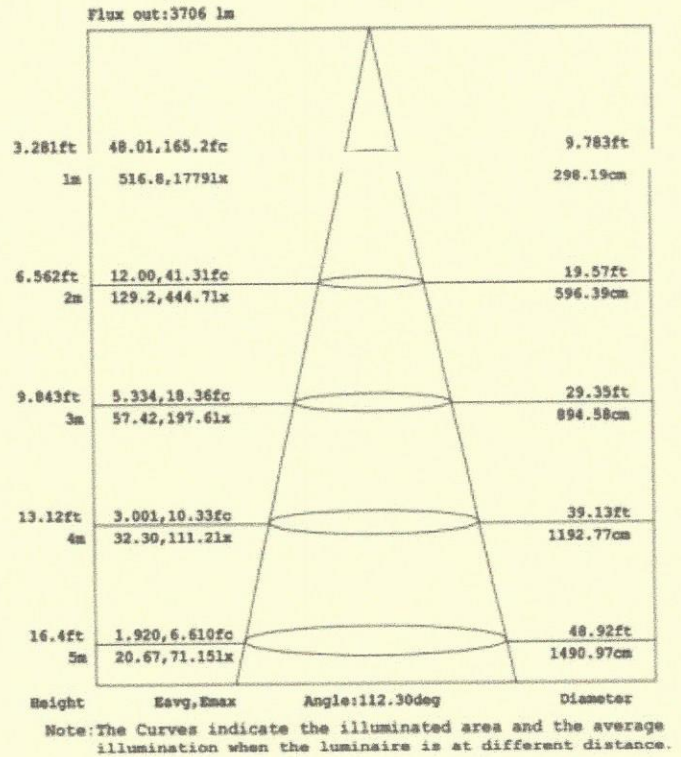

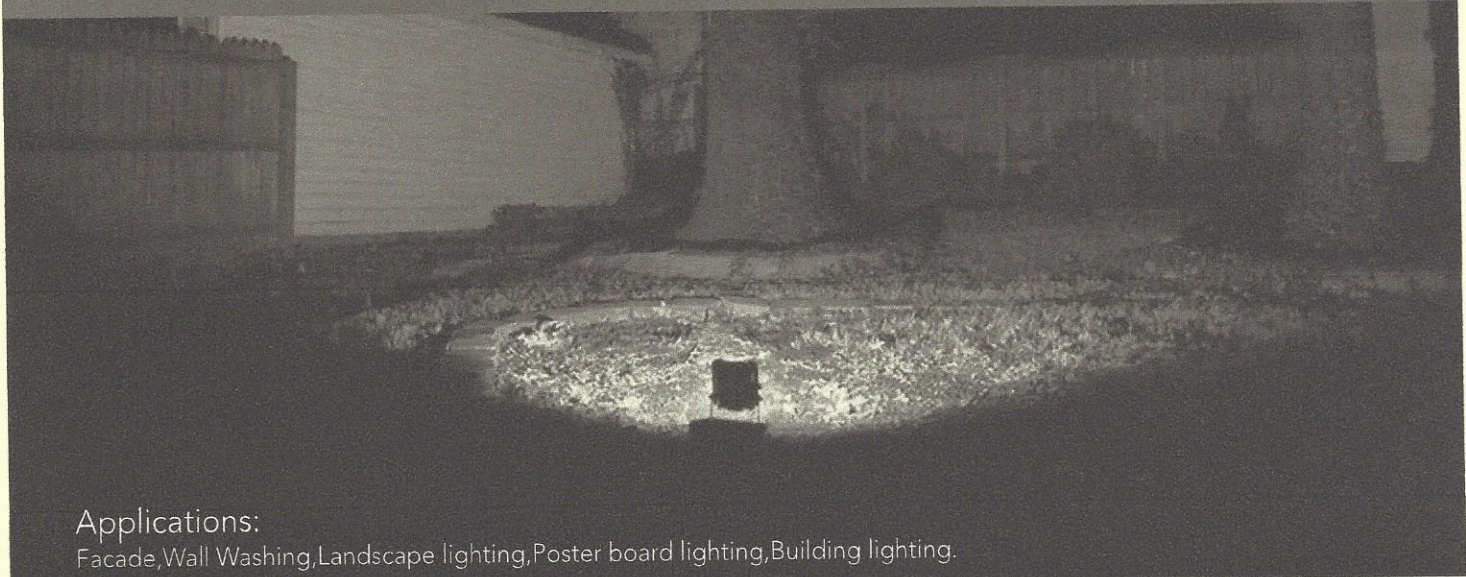

**Applications:**

Facade, Wall Washing, Landscape lighting, Poster board lighting, Building lighting.

**Features**

- Rugged aluminum housing with UV resistant powder coat finish offers outstanding corrosion protection.
- Lumen output 1500-5400lm with efficacy to 120lm/W
- Three installation for option: 1/2" knuckle mount or trunnion or wall mount
- Wide Flood beam spread 7H x 7V
- Long life LEDs lasting up to 50,000hours
- IP66 rated and suitable for use in ambients from -40°C to 45°C (-40°F ~ 113°F).
- UL wet location listed and DLC qualified

*STTAM Bid #19-17-2  
NOSC Alternate for Item 10  
Catalog # AGL Flood Light #3*

Size: 15W



Size: 30W

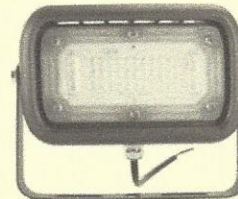

Size: 45W



**ELECTRICAL DATA**

Number Of Drivers	Driver Current (mA)	Nominal Power (W)	INPUT VOLTAGE (V)	CURRENT (Amps)
1	250	15	120	0.13
		15	208	0.07
		15	240	0.06
		15	277	0.05
1	430	30	120	0.25
		30	208	0.14
		30	240	0.13
		30	277	0.11
1	1100	45	120	0.38
		45	208	0.22
		45	240	0.19
		45	277	0.16

**PERFORMANCE DATA**

SYSTEM WATTS	VOLTAGE	DIST. TYPE	4000K(70CRI)		5000K(70CRI)	
			LUMENS	LPW	LUMENS	LPW
15W	120-277V	7Hx7V	1500lm	100 lm/W	1500lm	100 lm/W
30W	120-277V	7Hx7V	3000lm	100 lm/W	3000lm	100 lm/W
45W	120-277V	7Hx7V	5400lm	120 lm/W	5400lm	120 lm/W



*p9 1/2*

# ORDERING GUIDE

Example: FD15W27V50KBDB77

Fixture Type	Wattage	Voltage	CCT	CRI	Finish	Beam Angle
<input type="checkbox"/>	<input type="checkbox"/>	<input type="checkbox"/>	<input type="checkbox"/>	<input type="checkbox"/>	<input type="checkbox"/>	<input type="checkbox"/>
<b>FD</b> Flood Light	<b>15W</b> 15W <b>30W</b> 30W <b>45W</b> 45W	<b>27V</b> 120-277V	<b>30K</b> 3000K <b>35K</b> 3500K <b>40K</b> 4000K <b>50K</b> 5000K	<b>B</b> 70CRI	<b>D</b> Dark Bronze <b>B</b> Black <b>W</b> White	<b>B77</b> 7Hx7V

## DIMENSIONS

unit: mm/inch

*NOX Alternate for Item 10*

15W( Knuckle Mount)

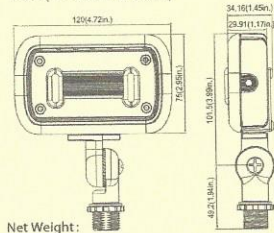

Net Weight:  
0.939lb

15W( Trunnion Mount)

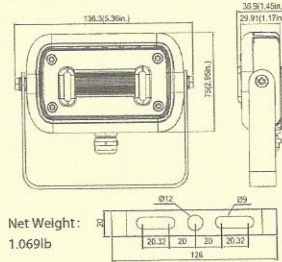

Net Weight:  
1.069lb

30W( Knuckle Mount)

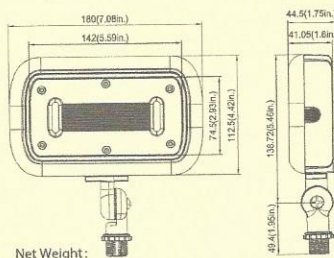

Net Weight:  
1.887lb

30W( Trunnion Mount)

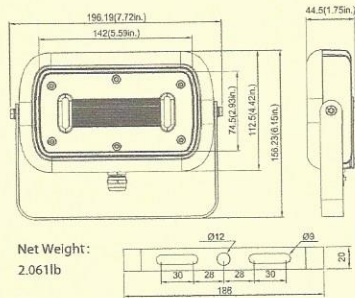

Net Weight:  
2.061lb

30W( Wall Mount)

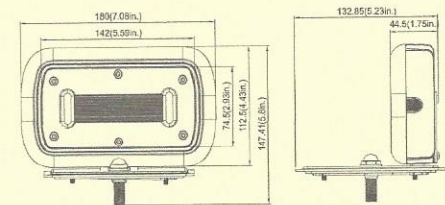

Net Weight:  
2.911lb

45W( Knuckle Mount)

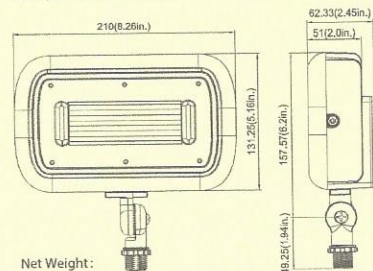

Net Weight:  
3.893lb

45W( Trunnion Mount)

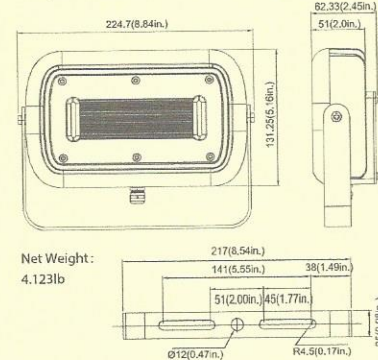

Net Weight:  
4.123lb

45W( Wall Mount)

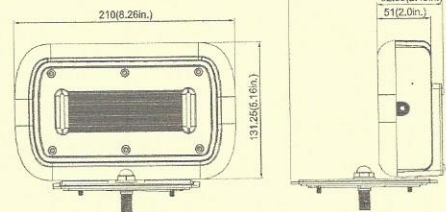

Net Weight:  
4.519lb



## MOUNTING

**1/2" Knuckle Mount**  
Die-cast aluminum knuckle provides flexibility in mounting from a variety of areas.



**Trunnion Mount**  
Die-cast aluminum trunnion is easily adapted to many surfaces and allows easy fixture aiming angles.



**Wall Mount (30W & 45W)**  
Wall Mount is easy to install for direct wall mounting with 1/2" conduit wiring or standard J-box mounting

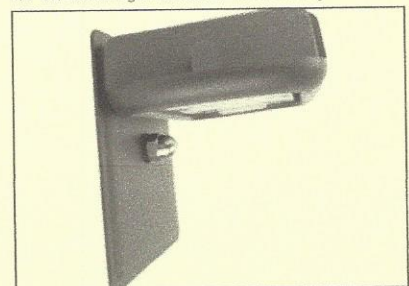

*2/2*

Project: STTan B.2 #19-17-2  
 Notes:  
 Type: \_\_\_\_\_ Date: \_\_\_\_\_  
 Catalog #: PT-HBT-100W-5k

# PORTORINDUSTRY

## LED UFO HIGHBAY

## UFO10-100W-110-H-50K

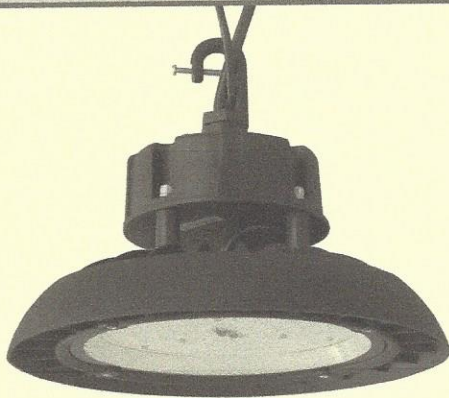

### APPLICATIONS

- Large Outdoor Spaces
- Large Indoor Spaces
- Industrial Areas
- Churches
- Swimming Pools
- Shopping Malls
- Warehouses
- Commercial
- Gymnasiums
- Retail Areas



### SPECIFICATION FEATURES

#### CONSTRUCTION

Advanced aluminum heat sink which provides excellent thermal transfer to extend component life. Professional light distribution technique.

#### ELECTRICAL

Luminaire is built with the highest quality 100-277VAC Sosen Drivers or Optional 347-480VAC Drivers and Water Resistant LED Chips.

#### ENERGY SAVINGS

Replaces 250W Metal Halide high bay. Energy savings are approximately 75% reduced.

#### CONTROLS AND DIMMING

0-10V Dimmable

#### INSTALLATION

Fixture comes standard with hook for suspension mount. Optional Ring Mount Available.

#### CERTIFICATION AND WARRANTY

UL Listed, FCC, CE, RoHS, & DLC Premium Listed on QPL.

5 Year Warranty.

### MODEL NUMBER(S)

MODEL #	WATTS	LUMENS PER WATT	LUMENS	COLOR TEMPERATURE	CRI	LIFE HOURS	INPUT VOLTAGE
UFO10-100W-110-H-50K	100	131	13,100	5000K	80	50,000	AC 100/277V
UFO15-150W-110-H-50K	150	130	19,600	5000K	80	50,000	AC 100/277V
UFO24-200W-110-H-50K	200	131	26,500	5000K	80	50,000	AC 100/277V
UFO24-240W-110-H-50K	240	130	32,000	5000K	80	50,000	AC 100/277V

# LED UFO HIGHBAY

# UFO10-100W-110-H-50K

## DIMENSIONS

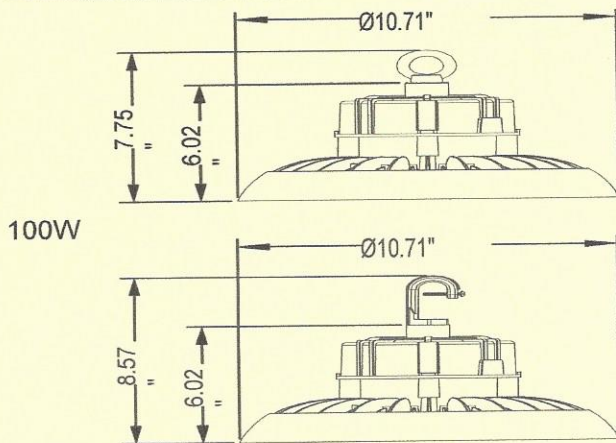

100W

## PHOTOMETRIC DATA

### LUMINOUS INTENSITY DISTRIBUTION DIAGRAM

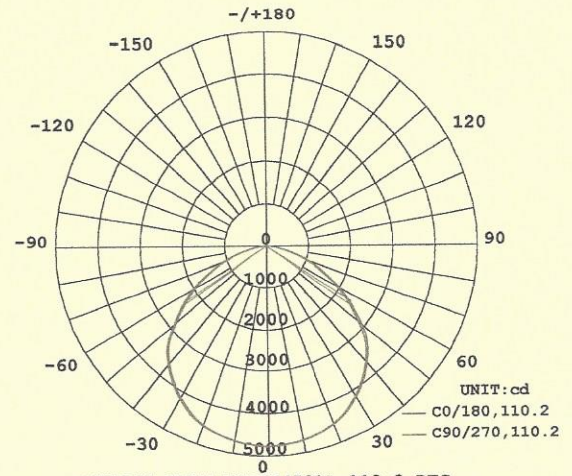

AVERAGE BEAM ANGLE (50%): 110.2 DEG

### MH (m) C0 PLANE ISOLUX DIAGRAM (UNIT: lx)

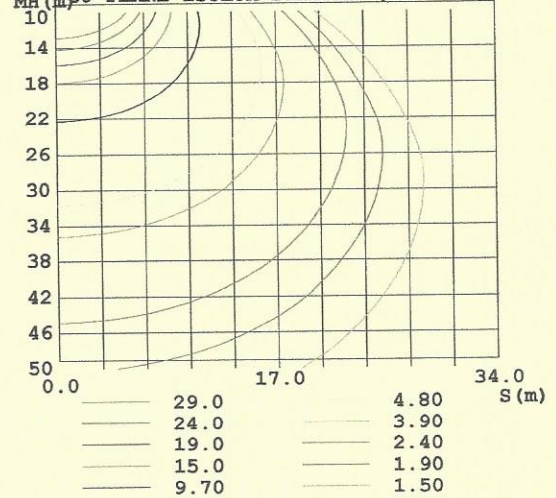

## TECHNICAL SUMMARY

UFO10-100W-110-H-50K	
INPUT WATTS	100 Watts
INPUT VOLTAGE	AC 100-277V AC277V-480V Optional
POWER FREQUENCY	50 Hz
EFFICACY	131 lm/W
DELIVERED LUMENS	13,100LM
CCT	5000K Other CCT Optional
CRI	RA>80
WORKING TEMPERATURE	-40°F - +122°F
STORAGE TEMPERATURE	-40°F - +158°F
IP RATING	IP65 Wet Location
CERTIFICATION	ETL CE FCC DLC Premium
WARRANTY TIME	5 Years
LED DRIVER	SOSEN
LED CHIP	2835 Samsung
OPTIONAL ACCESSORY	U-Bracket / Reflector
DIMMABLE	0 -10V Dimmable
POWER FACTOR	>0.9
THD	≤15%
PORTOR ITEM NUMBER	PT-HBT-100W-5K

## APPLICATION

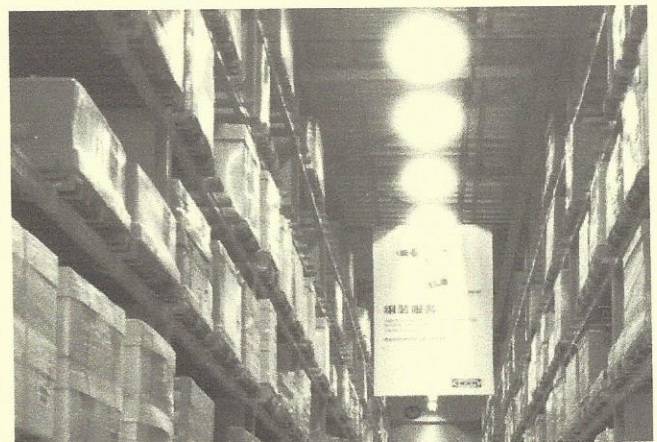



**ST. TAMMANY PARISH**

PATRICIA P. BRISTER  
PARISH PRESIDENT

**April 11, 2019**

Please find the following addendum to the below mentioned BID.

**Addendum No.:** 1

**Bid#:** 19-17-2

**Project Name:** LED Lighting

**Bid Due Date:** April 17, 2019

**GENERAL INFORMATION:**

---

1. Please delete Specifications and Pricing Sheet and replace with Specifications and Pricing Sheet -REVISED (Attached). The following lighting has been added to the bid:
  - EIKO, Model# LED3W1383/30/830-G5 is an approved equal for Item-12
  - ATG Electronics, Model# HBUF-100W-50-C is an approved equal for Item-13
  - WALSTAR Model#WL-T8A-15W1200 DIAB-40 is an approved equal for Item-1
2. Product information sheets for the approved equals are included as Attachment "A". (Attached)

**ATTACHMENTS:**

---

1. Specifications and Pricing Sheet –REVISED. pdf
2. Attachment "A". pdf

**<< End of Addendum 1 >>**



## **LED Lighting**

### **Bid # 19-17-2**

#### **Specifications and Pricing Sheet-REVISED**

The Parish is soliciting proposals for the purchase of new LED lighting. Prices remain in effect through **December 31, 2019**, with the option to extend for (1) one additional year, by written agreement of both parties. Any delivery and/or service charges must be included in the bid price. Quantities may vary; minimum orders shall not be required. St. Tammany Parish Government (Parish) reserves the right to award materials in whole, in part and/ or to multiple vendors. Bids must be submitted on the Pricing Sheet provided. **All fields must be filled in, NO blanks will be permitted. If the item is unavailable, enter N/A.**

The Parish facilities are comprised of buildings acquired over time which may require items not anticipated in this bid proposal request. In the event additional items and/or upgraded items are required by the Parish, the Bidder may provide the items with prior written approval by the Parish.

#### **Delivery Locations:**

Deliveries may need to be made to Parish facilities within St. Tammany Parish in addition to the following locations:

- Facilities Management, 21410 Koop Drive, Building C-1<sup>st</sup> Floor, Mandeville, LA 70741
- Justice Center, 701 N. Columbia St., Covington, LA 70433
- Safe Haven, 23592 Sparrow Road, Mandeville, LA 70448

Where specified on the bid sheets, prices shall be for the approved brand/states manufacturer or a prior approved equal by the Parish. Where the specifications do not indicate an approved brand for an item, the Parish has no preference. The name of any manufacturer mentioned in the specifications is for the purpose of establishing a minimum acceptable standard of quality desired by the Parish. All products bid must have prior approval as “approved equivalents”.

Should the Bidder desire to submit inquiries and/or request approval of an alternative product, Bidder shall submit make, model, supply catalog cut sheets and descriptive literature for the alternative product to the Procurement Department via email to [purchasing@stpgov.org](mailto:purchasing@stpgov.org) by 2:00 PM within seven (7) business days prior to the bid opening. Requests for approval of alternative products, shall include a copy of the bid and clearly identify the item(s) for which the equivalent item is being requested. The Parish shall review the inquiry and/or request for “approved

**LED Lighting**  
**Bid # 19-17-2**  
Specifications and Pricing Sheet-REVISED

equivalent” and issue an addendum within three (3) business days prior to the bid opening if prior approval submission is accepted as equivalent.

Bidder **must** acknowledge all addenda by entering the number the Parish assigned to EACH of the addenda that the Bidder is acknowledging.

The Bidder acknowledges receipt of the following:

**ADDENDA:** \_\_\_\_\_

**All fields must be filled in. NO blanks will be permitted. If the item is unavailable please enter N/A. “Price/Each” shall represent the cost for the specified item as well as any delivery charges (if applicable) to the location(s) indicated in this bid.**

<b>LED Lighting</b> <b>BID #19-17-2</b> <b>Specifications and Pricing Sheet -REVISED</b>					
Ref No.	Description	Make or Approved Equal	Approved Model No.	ea	Unit Price
Item-1	<b>4' LED tube</b> <17 watts Max - DIRECT WIRE -Bi-Pin base- Aluminum (No Glass) - 1800 lumens - 4000K (DLC CERTIFIED)	James Industry	ZY-T8-15W1200 BIXX	1	
		NaturaLED	LED15T8/FR18/840	1	
		TGS	834115-40-AB-P	1	
		WALSTAR	WL-T8A-15W1200 DIAB-40	1	
Item-2	<b>LED WALLPACK</b> half cutoff LED <105 watts >10,200 lumens 5000k IP65 <i>With PHOTOCELL</i> (DLC CERTIFIED)	LEDone	LOD-WP90W-50K	1	
		SYHDEE	SYHU-WP090NNXH-B(5000k)	1	
		NaturaLED	LED-FXTWP80/50K/DB	1	
		Sylvania Lighting	WALPAK3N/105UNV750/NC/BZ	1	

## LED Lighting

### Bid # 19-17-2

#### Specifications and Pricing Sheet-REVISED

		HALCO	WP2/CL90UBZ50/PC	1	
Item-3	<b>PAR38 LED FLOOD BULB</b> >1000 lumens <18 watts 4000K E26 base(DLC/ES CERTIFIED)	GE	LED18D38OW384040	1	
		Naturaled	LED15PAR38/OD/120L/FL/940	1	
		Sylvania Lighting	LED14APR38/DIM/840/FL40/22Y/GL3/W/RP	1	
		HALCO	PAR38FL15/840/ECO2/LED	1	
Item-4	<b>BR30 LED FLOOD BULB</b> >700 lumens <12 watts 4000K E26 base (DLC/ES CERTIFIED)	GREEN CREATIVE	8BR30G4DIM/840	1	
		TCP	LED12BR30D41K	1	
		HALCO	BR30FL10/840/LED	1	
Item-5	<b>BELLY PAN retrofit kit or 8' Conversion fixture</b> - for 8' fixtures - kit makes 2 8' T8/T12 in to 4 - 4' LED tubes (No certification required)	Epco	14050	1	
		X1LED	C2328X1	1	
		TGS	9919-4-A-C	1	
Item-6	<b>INCANDESCENT style LED bulb</b> <12 watts >800 Lumens 2700K/4000K (Order dependant)(DLC/ES CERTIFIED)	GE	LED10DA19/827	1	
		TCP	L60A19N1541K	1	
		Sylvania Lighting	LED9A19DIMO827U	1	
		HALCO	A19FR9/840/OMNI2/LED	1	
Item-7	<b>2 X 2 LED FLATPANEL</b> -4000K >2500 Lumens <40 watts (DLC CERTIFIED)	GreenTek	GT22-30W-CDS ADVANCED	1	
		Naturaled	LED-FXPNL25/2X2/840	1	
		Sylvania Lighting	PANELF1A/032UNVD840/22G/WH	1	
		HALCO	22EPL30/840/LED	1	

## LED Lighting

### Bid # 19-17-2

#### Specifications and Pricing Sheet-REVISED

Item-8	<b>2 X 4 LED FLATPANEL -4000K</b> 4200 Lumens <60 watts (DLC CERTIFIED)	GreenTek	GT24-40W-CDS ADVANCED	1	
		NaturaLED	LED-FXPNL40/2X4/840	1	
		Sylvania Lighting	SYL PANELF1A/040UNVD840/24G/	1	
		HALCO	24EPL50/840/LED	1	
		RAB	EZPAN2X4-50N/D10	1	
Item-9	<b>LED Cobrahead Style Roadway/Street light - 5000K</b> 10,000 lumens photocell included <120 watts (DLC CERTIFIED) Multi mount IP65	WESTGATE	STL-90W-50K-P	1	
		ENERGETIC LIGHTING	E1STA100L-750	1	
		HALCO	AL100/T4U50/7PRS	1	
Item-10	<b>LED Flood Fixture - 5000 Lumens 5000K &lt;60 Watts Multi Mount IP65 (DLC Certified)</b>	GreenTek	GT-FL06-50WAT1A1-57K	1	
		GREEN INOVA	GI-FL050A-50-B	1	
		Sylvania Lighting	SLMFLD1A/050UNV840/WF/BZ	1	
		HALCO	FL2/CL48BZ50/KN/LED	1	
Item-11	<b>R20 LED lamp - 400 Lumens - 2700k 8 watts max</b>	PROLED	R20FL6/827/LED	1	
		G.E.	LED7DP203B827/35	1	
Item-12	<b>Elevator LED R12 lamp - 120 lumens 10-18 volts- BA15S base - 2700k</b>	HALCO	1383/3WW/LED	1	
		LED ElevatorLight	LPO2D44FL2	1	
		EIKO	LED3W1383/30/830-G5	1	

# LED Lighting

## Bid # 19-17-2

### Specifications and Pricing Sheet-REVISED

Item-13	UFO style High Bay - 12,500 Lumens, 5000k, <120 watts, Multi Voltage input (DLC Certified)	TGS	CHB-E-100W-50K-W	1
		ATG Electronics	HBUF-100W-50-C	1
<b>All products must be DLC/Energy Star Certified where applicable and have a minimum 3 year Warranty</b>				

Company \_\_\_\_\_

Signature \_\_\_\_\_ Date: \_\_\_\_\_

Print Name \_\_\_\_\_

Title \_\_\_\_\_

Address \_\_\_\_\_

Telephone \_\_\_\_\_ email: \_\_\_\_\_

## LED Elevator Lights



BA15s  
base

BA15d  
base

2.4-3  
watts

20,000-  
30,000  
hours

125  
lumens

70+  
CRI

### features

- 3W LED replacement lamp for elevators and other small applications
- Instant-on with no warm up
- Lasts 20x longer than incandescent for reduced replacement and maintenance costs
- Uses up to 90% less energy than incandescent or halogen
- Shatter-resistant for reduced risk of injury and breakage
- RoHS Compliant; Mercury and Lead-Free
- 3 year limited warranty

**RoHS**  
Compliant

### performance

- Long life: 20,000 hours
- 125 lumens
- 80+ CRI
- CCT: 3000K
- Non-dimmable
- Meets ANSI specifications
- Contains no mercury or lead; classified as non-hazardous waste

### applications

- Elevators
- Property Management
- Hospitality
- Retail
- Aircraft
- Hospitals
- Office Lighting
- Shopping Malls
- Parking Garages



## LED Elevator Lights

### dimensions

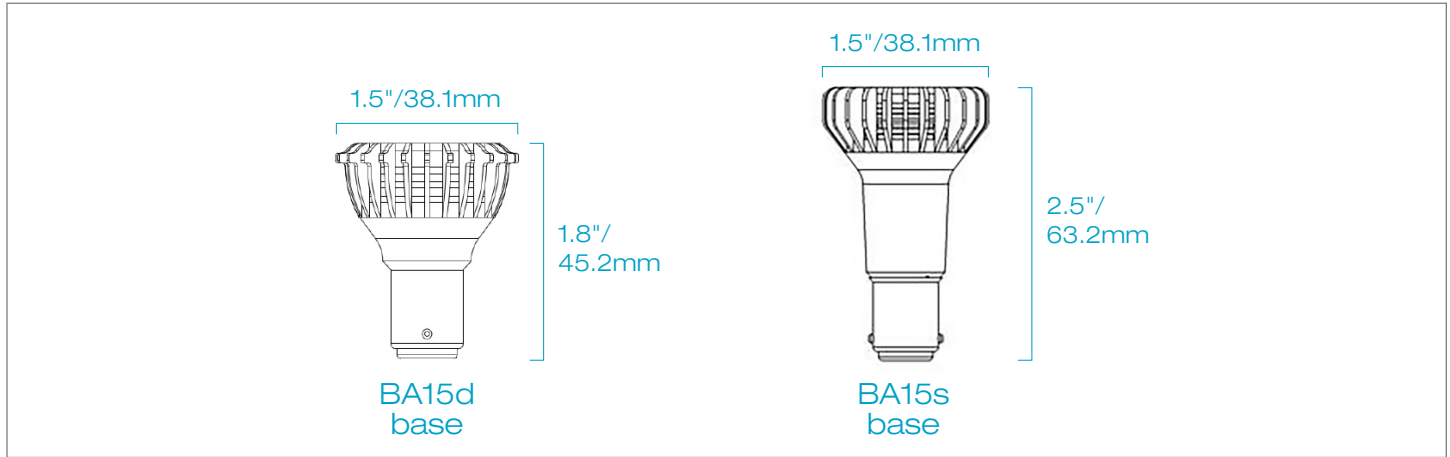

### ordering information

Order Code	Item #	W	Lm	CCT	CRI	Bm	MOL	Life/Hrs	Replaces Halogen
GBF non-dimmable BA15d base - 12V AC/DC									
<b>08895</b>	LED3WGBF/30/830-G5	3W	125	3000K	80+	30°	1.77"	20,000	20W GBF
<b>08900</b>	LED3WGBF/30/840-G5	3W	125	4000K	75+	30°	1.77"	20,000	20W GBF
1383 non-dimmable BA15s base - 12V AC/DC									
<b>08896</b>	LED3W1383/30/830-G5	3W	125	3000K	80+	30°	2.48"	20,000	20W 1383
<b>08899</b>	LED3W1383/30/840-G5	3W	125	4000K	75+	30°	2.48"	20,000	20W 1383
<b>07797</b>	LEDP-1383/30K**	2.4W	125	3000K	70+	30°	2.5"	30,000	20W 1383
<b>07798</b>	LEDP-1383/41K**	2.6W	125	4000K	70+	30°	2.5"	30,000	20W 1383

NOTE: use order code when ordering.

\*\*While supplies last

watch > like > follow



## Indoor

ATG's Helix High Bay is an evolution of commercial high bay lighting. The Helix High Bay is ideally deployed for use in distribution centers, manufacturing facilities, and large retail facilities with ceilings of 20 to 40 feet.



Luminaire	Helix High Bay	Type
Project		
Product		
Notes		

1. IP65 Rated
2. Superior glare prevention and light quality
3. Best mounted at a range of 20 to 40 feet



<b>Input Voltage (VAC)</b>	100-240/277 347-480
<b>CRI</b>	70+
	3500*
<b>*CCT (K)</b>	4000*
	5000
<b>PF</b>	0.9
<b>THD</b>	<20%
<b>L70 (Hours)</b>	95,000
<b>Color</b>	Black
<b>Housing</b>	Cast & Extrusion Aluminum
<b>Optic Types</b>	Clear
<b>Temperature Range</b>	-40°C to 49°C
<b>Warranty</b>	10 Years

\*contact sales for lead time:  
CCT 3500K, 4000K  
347-480 VAC

### Mounting

The luminaire is can be mounted by cable, bracket, or pendant\*. Maximum recommended installation height for the Helix High Bay is 40 ft. The slim profile allows for exceptionally versatile placement compared to traditional high bays.

\*pendant kit available, pole not included

### Electrical

Luminous efficacy is an excellent 140 Lm/W. Luminaire lifespan is rated at 95,000 hours. Standard input voltage is 100-240/277 and 347-480V drivers are available on all units. Fixture is IP65 rated.

### Construction

The Helix High Bay housing is formed from cast and extruded aluminum. Our streamlined manufacturing process delivers a more versatile product with a superior value proposition. Customers may order an optional aluminum shroud to further control light output.

### Optics

The Helix High Bay's clear, polycarbonate lens and rolled aluminum reflector enhance beam output for commercial uses. CCT is rated at 5000K for optimal performance in industrial environments. The CRI of 70+ provides color fidelity for visually sensitive tasks.

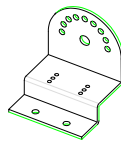
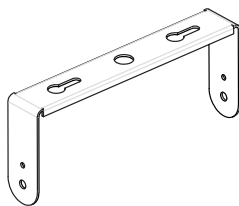

bracket

\*pendant kit available, pole not included

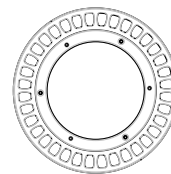

Bottom

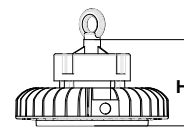

Profile

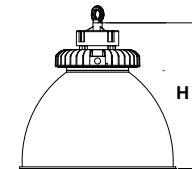

With Shroud

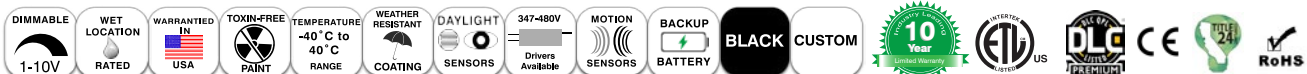



Part No.	Watts (W)	Efficacy (Lm/W)	Lumens (Lm)	Dimensions (L*W*H) Inches
HBUF-100W-50-C	99	141	14,000	10.24*5.75 with shroud 16*16.62 18*17.56
HBUF-150W-50-C	153	142	21,730	10.24*5.75 with shroud 16*16.62 18*17.56
HBUF-200W-50-C	196	140	27,500	11.42*6.63 with shroud 16*17.50 18*18.44
HBUF-250W-50-C	241	140	33,740	11.42*6.63 with shroud 16*17.50 18*18.44

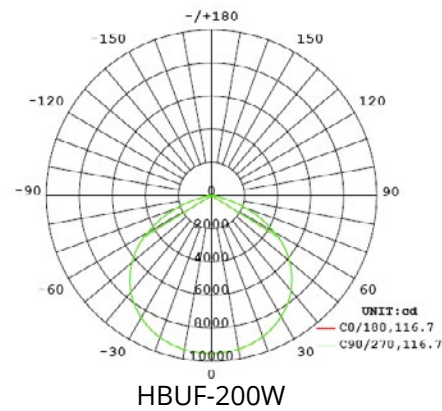
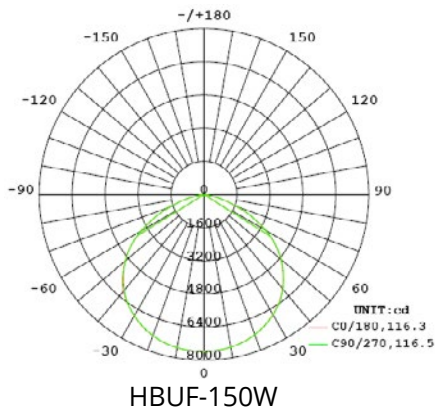

File Name	Wattage	System Wattage	Lumens	Efficacy
<b>5000K</b>				
HBUF-100W	100	99.37	14000	141
HBUF-150W	150	153.40	21746	142
HBUF-200W	200	196.30	27500	140
HBUF-250W	250	240.80	33735	140
<b>4000K</b>				
HBUF-100W	100	100.90	13512	133.92
HBUF-150W	150	151.60	20659	136.27
HBUF-200W	200	202.10	26125	129.27
HBUF-250W	250			

5000K -Acrylic Reflector-16 inch				Acrylic Reflector-22 inch					
File Name	Wattage	System Wattage	Lumens	Efficacy	File Name	Wattage	System Wattage	Lumens	Efficacy
HBUF-100W	100				HBUF-100W	100			
HBUF-150W	150	154.00	19323	125.47	HBUF-150W	150	154.50	18920	122.46
HBUF-200W	200	201.40	24677	122.53	HBUF-200W	200	201.10	24143	120.05
HBUF-250W	250				HBUF-250W	250			
<b>4000K</b>									
HBUF-100W	100		11920		HBUF-100W	100		11634	
HBUF-150W	150		18357		HBUF-150W	150		17974	
HBUF-200W	200		23443		HBUF-200W	200		22936	
HBUF-250W	250				HBUF-250W	250			

5000K -Acrylic Reflector-17 inch				Acrylic Reflector-18 inch					
File Name	Wattage	System Wattage	Lumens	Efficacy	File Name	Wattage	System Wattage	Lumens	Efficacy
HBUF-100W	100				HBUF-100W	100			
HBUF-150W	150	154.00	19323	125.47	HBUF-150W	150	155.50	16893	108.64
HBUF-200W	200	201.40	24677	122.53	HBUF-200W	200	202.10	21624	107.00
HBUF-250W	250				HBUF-250W	250			
<b>4000K</b>									
HBUF-100W	100		11920		HBUF-100W	100		10320	
HBUF-150W	150		18357		HBUF-150W	150		16048	
HBUF-200W	200		23443		HBUF-200W	200		20543	
HBUF-250W	250				HBUF-250W	250		25412	

# LED HYBRID T8 TUBES - ALU+PC

For DLC V4.1



## ► DESCRIPTION

Our DLC Qualified Aluminum hybrid tubes designed to emulate the look and feel of traditional 4-foot, 32-watt fluorescent T8 tubes, Operating ballast free, the lamps easily retrofit existing fixtures with a simple re-wire. Featuring an aerospace grade aluminum heat sink, ensuring beautiful illumination over a 50,000+ hour lifetime.

## ► FEATURES

1. Available in double end, single end, and ballast compatible models.
2. Ballast Compatible & Line Voltage
3. Excellent heat sink aluminum housing
4. Up to 135 Lumens per Watt.
5. Unified Glare Rating (UGR) <19
6. No UV or IR radiation
7. Own designed structure, zero risk of PC lens break out.
8. 5 years warranty.
9. DLC V4.1 listed.

## ► APPLICATION

Office, Meeting room, School, Hospital, Exhibition, Supermarket and so on

## ► ACCESSORIES

- FA8-Single Pin
- R17D end cap

## ► SPECIFICATION

LUMINOUS EFFICIENCY: 135LPW / 110LPW
CCT: 3000K/4000K/5000K
CRI: >80
BEAM ANGLE: 120°
VOLTS: 100-277VAC, 50/60Hz
POWER FACTOR: ≥.9
DIMMABLE: NON-Dimmable
LEDs: SMD2835
BODY TEMPERATURE: -20~45°C
Average Rated Life: 50,000 Hrs L70

MODEL	Length without PIN (mm)	Length with PIN (mm)
WL-T8A-10W1200 DIAB	1198	1213
WL-T8A-12W1200 DIAB	1198	1213
WL-T8A-15W1200 DIAB	1198	1213
WL-T8A-18W1200 DIAB	1198	1213
WL-T8A-22W1200 DIAB	1198	1213

## ► WIRE DIAGRAM

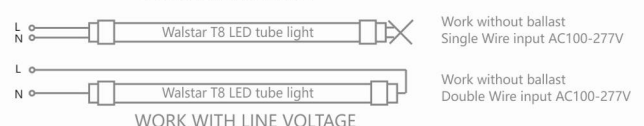
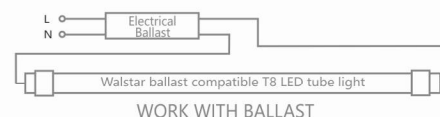



## LED HYBRID T8 TUBES - ALU+PC

For DLC V4.1

### ► SPECIFICATION

MODEL	VOLTS	WATTS	PF	LIGHT EFFICIENCY	LUMEN	CRI	UL	DLC
WL-T8A-10W1200 DIAB	120-277V	10W	> 0.9	130LPW	1300	>80	COMPLETED	YES
WL-T8A-12W1200 DIAB	120-277V	12W	> 0.9	130LPW	1560	>80	COMPLETED	YES
WL-T8A-15W1200 DIAB	120-277V	15W	> 0.9	130LPW	1950	>80	COMPLETED	YES
WL-T8A-18W1200 DIAB	120-277V	18W	> 0.9	130LPW	2340	>80	COMPLETED	YES
WL-T8A-22W1200 DIAB	120-277V	22W	> 0.9	130LPW	2860	>80	COMPLETED	YES

### ► ORDER INFORMATION

WL	XX	X	XXX	XXXX	XX	XX
		MATERIAL	WATTAGE	SIZE	DRIVER	TYPE
WALSTAR	T8-T8 tube	A - Aluminum+PC	10W-10Watt	1200 - 4'	DI - Built-in driver	AB-Type A+B
			12W-12Watt			
			15W-15Watt			
			18W-18Watt			
			22W-22Watt			